

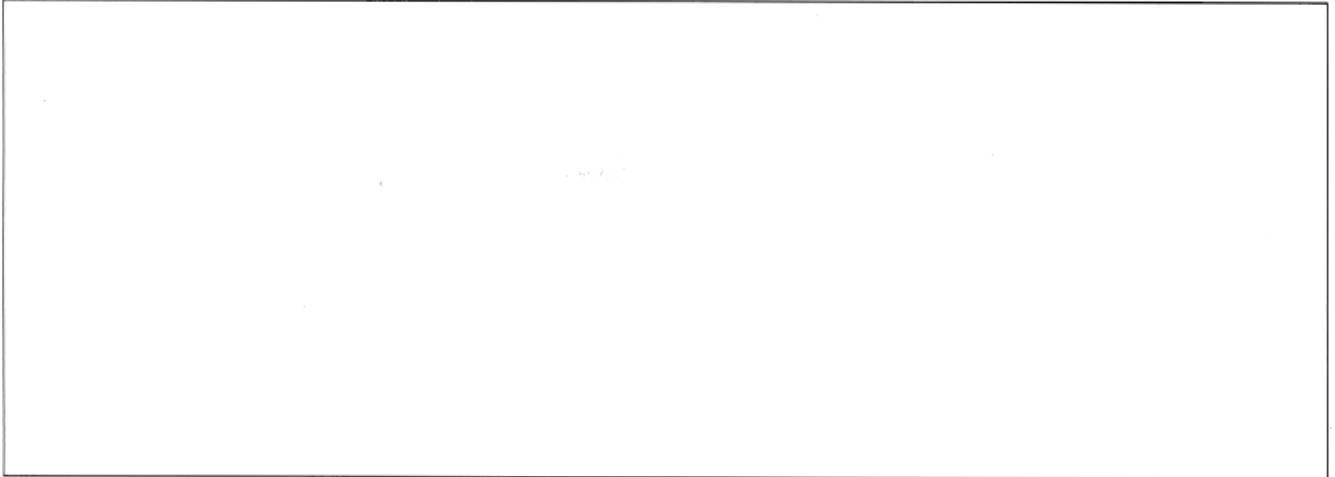

INSTRUCTION MANUAL  
**MVA**  
Millivolt Alarm

Form 191-701-00F

November 1984



### 1.1 SCOPE OF MANUAL

This manual contains a description, installation and operating instructions, and maintenance instructions for the DC Voltage Alarm (MVA). To support any maintenance that might be required, a description of the theory of operation is also included, and a list of replaceable parts is given. A list of recommended spares is also included.

### 1.2 PURPOSE OF EQUIPMENT

The DC Voltage Alarm (MVA) provides a signal that will operate an alarm system at a predetermined but adjustable value of DC voltage. The unit can also be supplied to operate the same or separate alarms at two different predetermined and adjustable values of DC voltage. As standard equipment, a lamp is supplied on the front panel for each trip to indicate visually the state (tripped or untripped) of the alarm.

### 1.3 GENERAL DESCRIPTION

The unit amplifies the applied input signal, adds the adjustable trip-point signal(s), and then uses the composite signal to drive the control amplifier(s). The signal for the external alarm system is produced by the closing or opening of a relay (or relays) controlled by the control amplifier(s). High stability is achieved through the use of feedback in each of the stages other than the control amplifier(s).

### 1.4 PHYSICAL DESCRIPTION

The unit consists of two printed-circuit boards, with one board wired to the other. One board contains the output components. The other, which can be considered the main board, contains the rest of the electronics. The boards are enclosed in a protective housing, and the entire assembly may be installed in a number of different ways. A bracket (supplied when specified in order) may be used to mount the assembly. For hazardous environments, an explosion-proof housing with a base containing up to four threaded hubs for wiring can be supplied. Also available are an enclosure that is oil-tight and dust-tight and another that is water-tight. Specific details for making electrical connections are given in Section 2, Installation Information.

### 1.5 SPECIFICATIONS

The specifications of the MVA are given in Table 1-1.

TABLE I-1. MVA SPECIFICATIONS

<u>INPUT SPANS</u>	0-5 millivolts 0-10 millivolts 0-25 millivolts 0-100 millivolts 0-400 millivolts 0-1 volt 0-5 volts 0-10 volts	Reqs. -LSA
<u>INPUT IMPEDANCE</u>	1 megohm minimum	
<u>ZERO ADJUSTMENT</u>	$\pm 10\%$ of span (minimum)	
<u>FRONT PANEL ADJUSTMENTS</u>		
<u>TRIP POINTS</u>	Multiturn front panel adjustment over a range of 0% to 110% of span	
<u>INPUT ZERO</u>	$\pm 10\%$ of span (minimum)	
<u>OUTPUT</u>	SPDT relay contacts 5 A @ 117 VAC non-inductive	
<u>PERFORMANCE</u>		
<u>REPEATABILITY</u>	Trip point repeats within $\pm 0.1\%$ full span	
<u>DEADBAND</u>	1% of span, standard	
<u>AMBIENT TEMPERATURE RANGE</u>	0°F to +150°F (-18°C to +65°C)	
<u>AMBIENT TEMPERATURE EFFECT</u>	Less than $\pm 0.01\%/^{\circ}\text{F}$ over above range	
<u>RESPONSE</u>	50 milliseconds for a step change of 1% of span beyond set points	
<u>ISOLATION</u>	Input, output, and power input are isolated with no DC connections between them. Both AC and DC powered units have this as standard	
<u>POWER INPUT</u>	117Vac, 240Vac, 50/60Hz $\pm 10\%$ standard 24Vdc, 45Vdc, $\pm 10\%$ optional 5 watts nominal	
<u>LINE VOLTAGE EFFECT</u>	AC or DC: $\pm 0.005\%/1\%$ line change	

### 1.6 MODEL NUMBERING SYSTEM

Model Numbers describe an instrument's type, functional range, and features. If all accompanying documentation of a unit should be missing, one can still "translate" the Model Number back into a working description of the unit by using the information in this paragraph as a reference.

#### BASIC EXAMPLE

MVA/0-25MV/D-X1X3/117AC [STD]

MVA, 0-25mV input full scale (from zero), dual trip output in X1-X3 configuration, 117Vac power

#### BASIC INSTRUMENT TYPE

MVA indicates DC Voltage Alarm

#### INPUT RANGE

25 millivolt span

#### OUTPUT RELAY MODES

- First Letter: S indicates single trip (upper trip point only)
- D indicates dual trip (both upper and lower trip points)
- X1X3: X1 indicates that upper trip-point relay is energized when input signal is below upper trip point (fail-safe mode); standard unless other option requested
- X3 indicates that lower trip-point relay is energized when input signal is above lower trip point (fail-safe mode); standard unless other option requested

#### POWER INPUT

- DC: DC power, 24 VDC  $\pm 10\%$  unless stated otherwise, e.g., 45 VDC,
- AC: AC power, 117 VAC  $\pm 10\%$  unless stated otherwise, e.g., 240 VAC

#### HOUSING

Table 1-2 lists the option letters in the model number and explains their meanings.

TABLE 1-2. EXPLANATION OF OPTION LETTERS IN MODEL NUMBERS

-AD	ADJUSTABLE DEADBAND
-AR	FACTORY SET RESPONSE TIME DELAY
-DC	DC POWER (24, 45 Vdc $\pm$ 10%)
-DD	DOWNSCALE BURNOUT DRIVE
-DPDT	DOUBLE-POLE-DOUBLE-THROW RELAY OUTPUT
-FU	FUSE
-HS	HERMETICALLY SEALED RELAY OUTPUT
-LSA	LOWER SPANS (0-5mV)
-MR	MANUAL RESET - EXTERNAL CONTACT CLOSURE RESET
-PR	SOLID-STATE POWER RELAY
-TT	PRECISION 10-TURN DIAL
-UD	UPSCALE BURNOUT DRIVE

### INSTALLATION INFORMATION

#### 2.1 GENERAL INSTALLATION INFORMATION

Installation, in general, consists of adjustment (when required), mechanical mounting, and making the electrical connections to the unit. The following paragraphs describe the necessary procedures.

#### 2.2 ADJUSTMENT

Units are checked for proper performance at the factory before they are shipped. However, unless adjustment was requested to a specific trip point (or pair of trip points), the unit should be adjusted by the user before the unit is placed in service.

#### NOTE

Adjustments should not be made in the field on units that are adjusted at the factory to a value (or values) specified in the purchase order. Units that are adjusted at the factory to customer's specifications have protective caps over the UPPER and LOWER trip point potentiometers; do NOT remove these caps.

A continuously adjustable DC voltage input signal source with a monitoring device for determining the input amplitude is required for adjustment. The input voltage monitoring device must have an accuracy within  $\pm 0.05\%$  or better.

In the following procedure, it is assumed that the unit being adjusted is a dual-trip unit (with both upper and lower trip points) and with both upper and lower deadband adjustment options included. If the unit actually being adjusted does not have all these features, simply perform those steps that apply to that particular unit and omit the others.

To adjust a unit, proceed as follows:

- a. Connect unit and test equipment as shown in Figure 2-1. Initially turn the trip point, ZERO and DEADBAND potentiometers fully counterclockwise. If the trip point potentiometers have 10-turn dials (TT option), carefully turn each dial to the desired setting instead of fully counterclockwise. It is assumed here that the LOWER trip point dial is set to a number greater than 0 and that the UPPER trip point dial is set to a number less than 100.

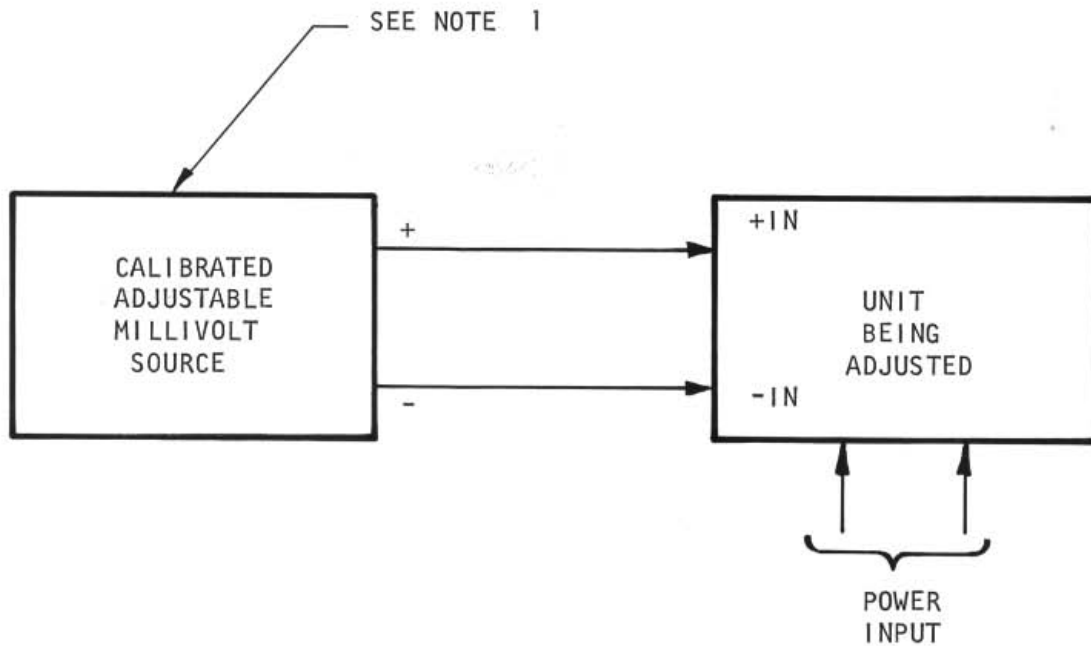

## NOTES:

1. INPUT VOLTMETER MUST BE ACCURATE TO WITHIN  $\pm 0.05\%$ .

Figure 2-1. Test Equipment Setup For Adjustment Of Unit

**INSTALLATION INFORMATION**

- b. Apply power input to the unit and apply input signal voltage equal to the value of the lower trip point.

NOTE

Refer to paragraph 1.6 for information on how to use the model number to obtain the output configuration.

- c. Refer to Table 2-1 to determine which state of a lamp corresponds to a given state of the associated output section for a given configuration of that section. Turn the ZERO potentiometer clockwise until the lower section of the unit trips, and then turn the potentiometer counterclockwise until this section just untrips.
- d. Slowly turn the LOWER trip point potentiometer clockwise until the lower section of the unit just trips.

TABLE 2-1. OUTPUT STATES VS. OUTPUT CONFIGURATIONS

OUTPUT		ALARM STATE	OUTPUT LAMP & RELAY STATE
CONFIGURATION			
UPPER	X1	TRIPPED	LAMP "OFF" (K1 DEENERGIZED)
		UNTRIPPED	LAMP "ON" (K1 ENERGIZED)
	X2	TRIPPED	LAMP "ON" (K1 ENERGIZED)
		UNTRIPPED	LAMP "OFF" (K1 DEENERGIZED)
LOWER	X3	TRIPPED	LAMP "OFF" (K2 DEENERGIZED)
		UNTRIPPED	LAMP "ON" (K2 ENERGIZED)
	X4	TRIPPED	LAMP "ON" (K2 ENERGIZED)
		UNTRIPPED	LAMP "OFF" (K2 DEENERGIZED)



### INSTALLATION INFORMATION

- e. Check, and readjust if necessary, the ZERO potentiometer by verifying that the lower section of the unit can be tripped and untripped with the LOWER trip point potentiometer. Leave this section of the unit in the tripped condition with the potentiometer adjusted almost, but not quite, fully counterclockwise. If the unit has the TT option, return the LOWER trip point dial to the desired setting, and make sure that this section of the unit is in the tripped condition.
- f. Turn the LOWER DEADBAND potentiometer fully clockwise. Increase the input voltage to the value of the upper limit of the lower deadband, and then slowly turn the LOWER DEADBAND potentiometer counterclockwise until the lower section of the unit returns to the untripped condition.
- g. Recheck the trip and return action of the lower section of the unit at input voltages equal to the lower trip voltage and the upper limit of the lower deadband to verify that the unit trips.
- h. Increase the input voltage to the value of the upper trip point.
- i. Turn the UPPER trip point potentiometer clockwise until this section of the unit is in the untripped condition, and then slowly turn the potentiometer counterclockwise until this section trips again. If the unit has the TT option, return the UPPER trip point dial to the desired setting, and make sure that this section of the unit is in the tripped condition.
- j. Turn the UPPER DEADBAND potentiometer fully clockwise. Decrease the input voltage to the value of the lower limit of the upper deadband, and then slowly turn the UPPER DEADBAND potentiometer counterclockwise until the upper section of the unit returns to the untripped condition.
- k. Recheck the trip and return action of the upper section of the unit at input voltages equal to the upper trip voltage and the lower limit of the upper deadband to verify that the unit trips at the desired upper trip point and exhibits the desired deadband.
- l. After step (k) has been successfully completed, remove the input signal and then turn off the power input to the unit.

### INSTALLATION INFORMATION

#### 2.3 MECHANICAL INSTALLATION

Figure 2-2 shows the outline dimensions and other installation requirements. Be sure to observe the applicable special procedures and precautions given with the illustration. Although the units are designed to operate in free air at quite a high ambient temperature, it is advisable if possible to mount the unit on a surface made of material that can serve as a heat sink.

#### 2.4 ELECTRICAL CONNECTIONS

All electrical connections are made to the terminal blocks in the unit. The terminals to be used for the electrical connections are indicated in Figure 2-3. The following paragraphs provide additional information on wiring the unit.

##### 2.4.1 General Wiring Techniques

No special wire or cable is required for signal connections to the unit. To avoid transients and stray pickup, it is recommended that twisted conductors be used where they are run close to other services (such as power wiring). On open units supplied with a snap-off cover, dress all wiring up through the opening in the bottom of the cover. Spade-lug connectors are recommended for all wire terminations. All terminals are supplied with 6-32 screws long enough to easily accept three spade-lug connectors.

##### 2.4.2 Power Connections

A given unit is designed to be operated from either a DC power source or an AC power source. Refer to paragraph 1.6 for information on how to use the model number to determine the type of power required.

On DC-powered units, the DC terminal is connected to the + (positive) side of the source, and the DCC terminal is connected to the - (negative) side. The DC source should be regulated to within  $\pm 10\%$  of the nominal voltage and should be capable of delivering 3 watts.

On AC-powered units, 117 volts AC  $\pm 10\%$ , 50/60 Hz, 3 VA nominal power is required. The AC terminal should be connected to the ungrounded or "hot" side of the supply, if possible, and the ACC terminal is connected to the common or neutral side. The GND terminal is the mechanical case connection.

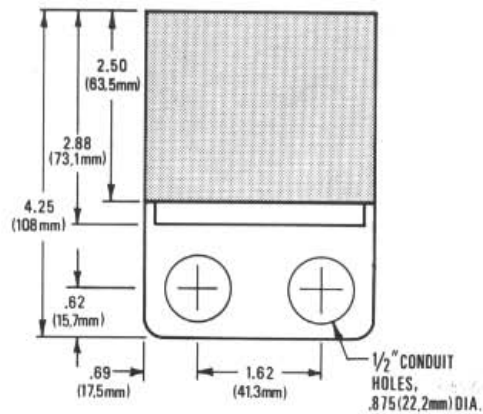

TOP VIEW

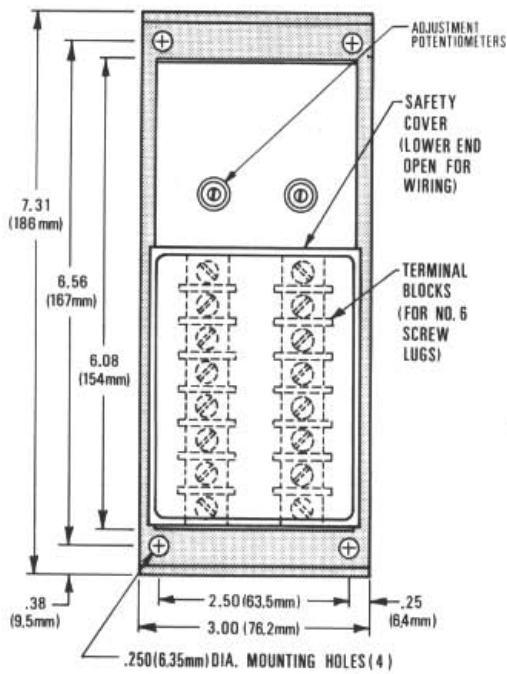

FRONT VIEW

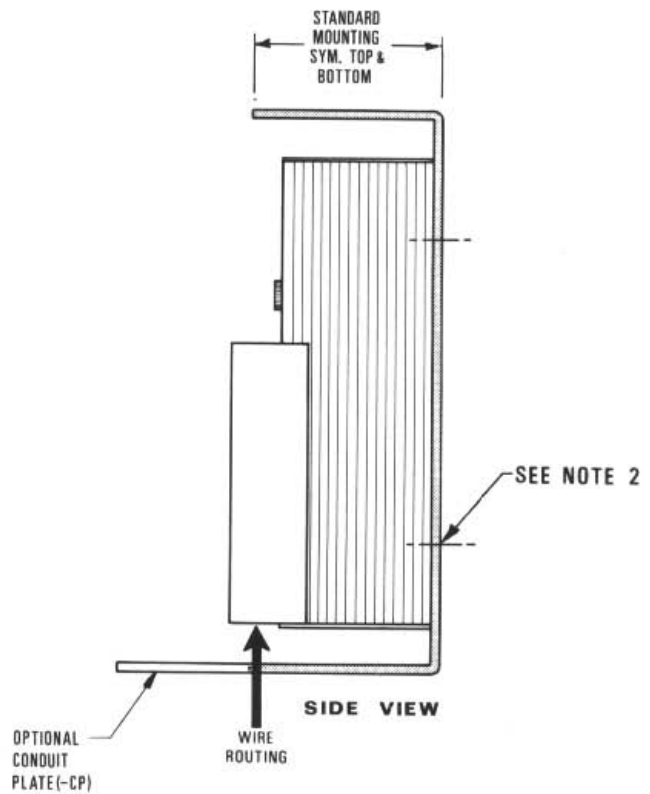

SIDE VIEW

NOTES:

1. Complete Model No. and Serial No. are permanently marked on the identification plate located at the upper end of the terminal blocks.
2. When extra-compact mounting is required for rack or portable installation, the C-shaped mounting bracket may be removed and the two threaded inserts (located 4.00 inches apart) may be used for mounting, using 6-32 NC machine screws.

CAUTION

WHEN THE REAR INSERTS ARE USED FOR MOUNTING, BE SURE THAT THE MOUNTING SCREWS DO NOT PROTRUDE MORE THAN 1/8 INCH INTO THE UNIT.

Figure 2-2. Outline and Installation

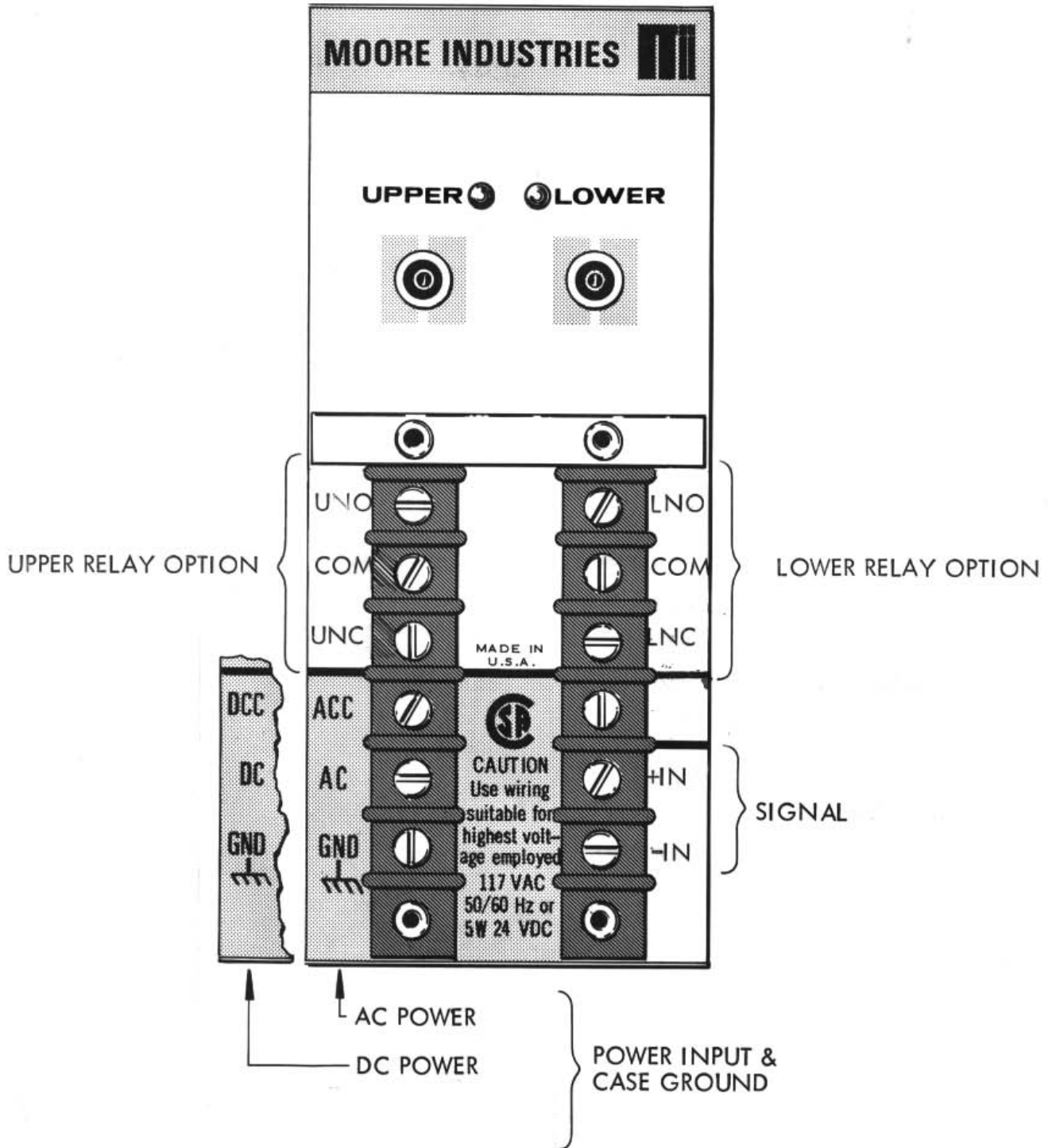

Figure 2-3 Electrical Connections For Standard Unit

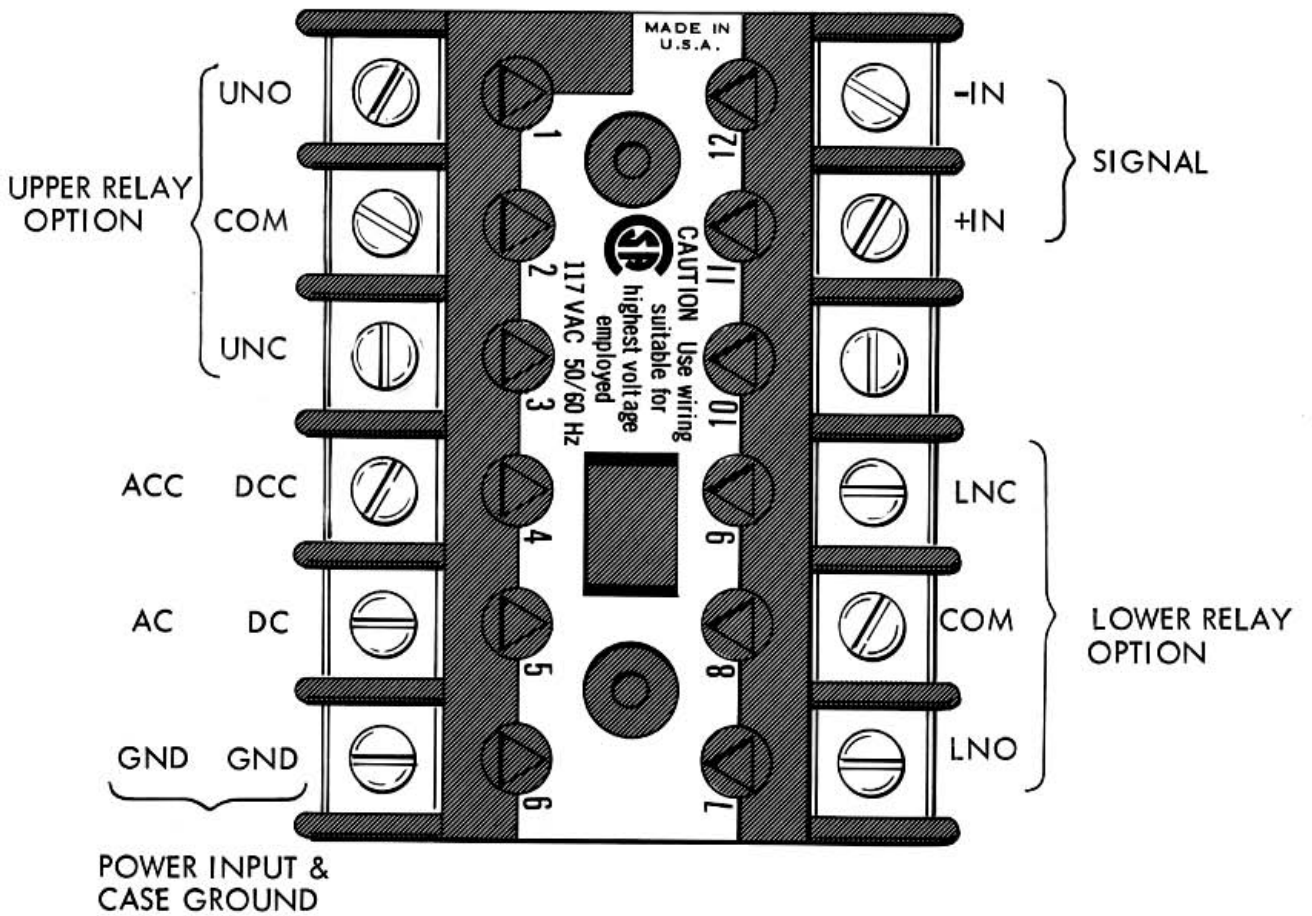

Figure 2-3. Electrical Connections For -EX (Explosion Proof) Housing Mounted Single Unit & -PST Std. Plug-In Units

**OPERATING INFORMATION****3.1 OPERATING PROCEDURE**

Once adjusted and installed, the unit may be operated unattended. The only controls on the outside of the unit are the ZERO and trip point potentiometers which, after initial adjustment, need no further attention. A lamp associated with each output relay is included on the unit as a standard feature. These lamps inform the operator when alarm condition has occurred. Note carefully, however, that an illuminated lamp does not necessarily indicate an alarm condition, since a relay may be energized either with a normal (non-alarm) input signal (X1 and X3 output configurations, fail-safe operation) or with an alarm input signal (X2 and X4 output configurations, non-fail-safe operation). There are no other indicators on the unit. Because the circuit uses highly reliable solid-state components, except for relays, the unit should operate virtually maintenance-free for a long period of time. However, if a malfunction should occur, refer to Section 5 for maintenance information.

A unit may become warm during operation, especially where the ambient temperature is rather high. This is perfectly normal and should not be a cause for concern unless a malfunction is also observed.

## THEORY OF OPERATION

## 4.1 INTRODUCTION

This section describes the theory of operation of the unit. The description is based on a unit that has dual trips in the X1, X3 configuration (see main schematic diagram) and two deadband adjustments. If the particular unit supplied does not have all these features, simply disregard those elements of the schematic and the accompanying text that do not apply.

## 4.2 CIRCUIT DESCRIPTION

The main schematic diagram of the unit is near the end of this manual. Except where otherwise indicated, refer to this diagram when reading the following paragraphs.

4.2.1 Description Of AC Power-Supply Circuit

In a unit that is operated from AC power, the power supply consists of a power transformer, rectifiers, filters, and regulators to produce positive and negative voltages with respect to common. Referring to the main schematic diagram it is seen that AC power is filtered by VSI and applied to the primary of power transformer T1. The filter elements serve to prevent line noise or spikes from getting into the unit. AC voltage from the center-tapped secondary of T1 is rectified by CR6 and CR9 to produce positive DC output, and by CR7 and CR8 to produce negative DC output. These outputs are filtered by C9-C11 and C8-C12 and regulated by R26-CR12 and R25-CR11 to produce outputs of +12 and -12 volts as operating voltages for the unit. A somewhat higher positive voltage (point C) is utilized for operating the output relay(s) and lamp(s). The other (blue-violet) secondary of T1 provides AC input to the circuit that develops the DC source for the zero-adjust circuit.

4.2.2 Description Of Power-Inverter Circuit

The components of the power inverter are mounted on a printed-circuit board attached to the main board. Descriptions of the power-inverter circuit of the unit are given in the following paragraphs.

4.2.2.1 Power-Inverter Circuit

Drawing 400-404-00 is the schematic diagram of the power inverter (PCA). When the unit is ordered for use with DC power, the power inverter is used instead of the AC source (T1) shown on the main schematic diagram. The DC applied to the power inverter is converted to a square wave of approximately 3 KHz by Q1, Q2, and the primaries of T1 (PCA schematic diagram), functioning as a DC-to-AC inverter. Filter L1-C1 on PCA prevents the 3-KHz signal from getting back into the external DC source. CR1 provides protection against damage from inadvertent application of DC of incorrect polarity. The square-wave output from center-tapped secondary 8-13 is applied to CR6 through CR9 (main schematic), and the action from this point is identical to that described in paragraph 4.2.1. Secondary 17-16 of T1 on PCA supplies AC voltage to points D and E of the zero-adjust circuit (main schematic diagram).

#### 4.2.3 Description Of Input Buffer Circuit

The input buffer consists of IC1 and associated components. The stage serves to isolate the input-signal source from later stages in the unit, so adjustment in the value of trip point(s) will not affect the input signal. A small voltage, adjustable with the ZERO potentiometer, is added to the input signal to modify the live zero and allow the lower section of the unit to trip at the desired lower trip point. The circuit that supplies this voltage consists of CR3, an associated filter capacitor, resistors, and zener diodes, plus a bridge circuit that includes an adjustable element. The AC voltage supplied to points D and E is applied through R13 to half-wave rectifier CR3. C10 filters the pulsating output from CR4 and the resulting DC voltage is applied through R14 to zener diode CR4 for initial regulation and then through R15 to zener diode CR5 for final regulation to 6.2 volts. This voltage is then applied to the bridge circuit that includes the ZERO potentiometer as the adjustable element.

R10, R16, R17 and the ZERO potentiometer from the bridge circuit, and the output from CR5 is applied between the junction of R16 and R17 and the junction of R10 and terminal 3 of the ZERO potentiometer. The wiper of the ZERO potentiometer is connected to common and is at one corner of the bridge output; the junction of R12 and R16 which is also connected to the -IN terminal, is at the other corner of the bridge output. Thus, moving the wiper of the ZERO potentiometer changes the potential of the -IN terminal (and, therefore, the +IN terminal) with respect to common. The ZERO potentiometer is adjusted so the composite signal drives IC1 to make the lower section of the unit trip with the input voltage equal to the lower trip point and with the LOWER trip point potentiometer not turned fully counterclockwise, or, in a unit with the TT option, with the LOWER trip point dial at the desired setting.

The composite signal at the +IN terminal is applied through R6 and R22 to the non-inverting input (pin 3) of IC1, which is used as a buffer with sufficient gain and a low output impedance to reliably drive the following stages. C4, C5 and R22, together with IC1, form an active low-pass filter with a very sharp cutoff characteristic to remove any noise or other high-frequency components from the signal applied to IC1. R2 and R3 provide feedback to the inverting input and thus determine the gain of IC1. R2 is selected to establish the gain of IC1 according to the range of the applied input signal. The  $\pm 12$ -volt outputs from the power supply are used to power IC1.

#### 4.2.4 Description Of Upper Comparator Circuit

The upper comparator consists of IC2 and associated components. The output from IC1 is applied through the UPPER TRIP PT. ADJ to the inverting input (pin 2) of IC2. With no input signal applied a portion of the negative voltage developed by zener diodes CR16, is supplied to pin 2 of IC2. This negative voltage at pin 2 causes the output of IC2 (pin 6) to be positive, consequently CR18 and CR19 are both reverse-biased.



**THEORY OF OPERATION**

When the input signal is applied and exceeds the voltage set by the UPPER LEVEL TRIP PT. ADJ. the output of IC2 becomes negative forward biasing CR18 and CR19. With CR18 forward feedback is applied to IC2 and with CR19 forward biased a negative signal is applied to the relay driver. The level of the signal fed back to the non-inverting input (pin 3) of IC2 is determined by the setting of the UPPER LEVEL DEADBAND ADJ.

When the applied input again becomes normal (i.e., the output from IC1 falls below the upper trip point), the output of IC2 will not immediately return to its original positive state. Instead, because feedback through CR18 keeps pin 3 less positive than before, the output from IC2 remains negative until the driving signal from IC1 decreases to a value below that of the signal at pin 3. When this occurs, the output of IC2 abruptly returns to its original positive state and CR18 is no longer forward-biased. Because the level of signal at pin 3 shifts when CR18 is conducting compared with when it is not conducting, the value of input signal at which IC2 returns to positive output is somewhat lower than that at which the change occurred from positive to negative output (upper trip point exceeded). The difference between these two values is called the upper deadband, and it is determined by the adjustment of the UPPER DEADBAND potentiometer.

#### 4.2.5 Description Of Lower Comparator Circuit

The lower comparator circuit consists of IC3 and associated components. The circuit description of the lower comparator circuit is the same as the upper comparator circuit described in paragraph 4.2.4.

#### 4.2.6 Description Of Upper Relay Driver

The upper relay driver consists of Q203, Q204, and associated components. Whether the output relay is energized or deenergized below the trip point is determined by the connection of the relay status selection jumper. When JX1 is connected and the input signal to IC1 is below the upper level trip point, the output of IC2 is positive. With the output of IC2 positive, Q203 is conducting, thus K1 is energized. As the input signal increases above the trip point Q203 is turned off and K1 is deenergized. When JX2 is connected and the input signal to IC1 is below the upper level trip point, the output of IC2 is positive. With the output of IC2 positive, Q203 is conducting and Q204 is turned off, causing relay K1 to be deenergized. As the input increases above the trip point, Q203 is turned off and Q204 is turned on, causing K1 to be energized.

#### 4.2.7 Description Of Lower Relay Driver

The lower relay driver consists of Q201, Q202 and associated components. The description of the lower relay driver is the same as the upper relay driver described in paragraph 4.2.6.

## MAINTENANCE INFORMATION

### 5.1 INTRODUCTION

This section contains information on maintenance of the unit. General troubleshooting procedures are given, using conventional signal-tracing techniques. Precautions and special techniques used to replace components are also described.

### 5.2 PERIODIC MAINTENANCE

It is suggested that the adjustment of the unit be checked approximately every 6 months as described in Section 2. No other periodic maintenance is required.

### 5.3 CORRECTIVE MAINTENANCE

The following paragraphs provide information on corrective maintenance of the unit. Corrective maintenance should be carried out only by qualified personnel who have read and thoroughly understand the description of circuit operation given in Section 4.

#### 5.3.1 Disassembly

To troubleshoot the unit, it is first necessary to disassemble it so the circuit board is exposed. These steps are described in the following paragraphs. In all cases, disconnect the input signal and turn off the power input before disassembling the unit.

##### 5.3.1.1 Disassembly Of Standard And -CP Units

To disassemble a standard or -CP unit, remove the unit from its installed position. If the mounting bracket is used, separate it from the unit by removing the two countersunk screws at the rear of the unit. After the unit has been removed from its installed position, disassemble the unit as follows to gain access to the circuit board:

- a. Remove the two front HEX-HEAD screws at the top of the unit.
- b. Remove the four HEX-HEAD screws at the bottom of the unit.
- c. Slide the front panel (with the circuit board still attached) down and free of the sides of the case. Points on the circuit board may now be reached for troubleshooting. It is suggested that the case be used as a container for storing the removed hardware.

### 5.3.2 Troubleshooting

The schematic diagram(s) includes flagged numbers or letters at various points in the circuit. Table 5-1 gives the voltages and waveforms at these points for specified input-signal conditions. The assembly drawing(s) shows the physical locations of the parts on the circuit board. Bear in mind that the circuit board is protected with a moisture-resistant coating. Therefore, it may be necessary to use a needle-point probe and exert a fair amount of pressure to break through the coating when it is desired to observe the signal or voltage at a specific point. When connecting a probe to a component on the circuit board, exercise care to make sure the probe does not short-circuit to an adjacent component. In general, troubleshooting is carried out by tracing the signal with an oscilloscope and referring to the schematic diagram(s) to determine what component might be causing an observed abnormal indication. If the original symptom was a complete failure of the unit to operate, the most logical components to suspect are those associated with the power supply in the unit. If the unit tripped (or failed to trip) with an applied input that should have produced the opposite condition, check the output from the power supply and, if these are normal, apply a standard input signal and trace the resulting signal through the unit.

### 5.3.3 Component Replacement Techniques And General Precautions

Replace all defective components with identical parts. Refer to the assembly drawing(s) for a list of replacement parts. The letter S and a number, all enclosed in a circle, appear after the description of certain parts in this list. The number indicates the number of spares recommended to be kept on hand for that part, per unit, for up to ten units of the same type. For more than ten units, a spares complement of 10% on the indicated parts should be used.

Most parts used in the unit are quite small and are located in a confined area. Therefore, small hand tools are a necessity when servicing the unit. The following is a summary of the general techniques and precautions that should be observed to prevent damage to components in the unit:

- a. Use a transformer-operated low-voltage soldering iron with a grounded tip and rated at not more than 50 watts. A temperature-controlled tip is desirable.
- b. Use extreme care when unsoldering the leads to any component. Do not keep the soldering iron on a point for more than a few seconds at a time. Use a suction-type solder-removing tool (solder sucker) as an aid in unsoldering transistors and integrated circuits. The protective coating on the unit may be removed with trichlorethane or equivalent. Be sure adequate ventilation is provided when using this or any other chemical.

## MAINTENANCE INFORMATION

NOTE

Unused connections on integrated circuits are left unsoldered to aid in removal. Refer to the assembly drawing for more complete information.

- c. Do not excessively bend or twist the leads of small components; they break easily.
- d. Before removing a component, observe the lead dress. Be sure that the lead dress of the replacement is the same as that of the original.
- e. Remove all flux from soldered joints with trichlorethane or equivalent.

NOTE

Units that were adjusted at the factory to customer's specifications have protective caps over the UPPER and LOWER trip point and ZERO potentiometers. These caps must be removed so the unit can be readjusted. LIFT, DO NOT TWIST, the caps off, using a screwdriver tip as a prying tool. Snap the caps back in place, WITHOUT TWISTING, when readjustment has been completed.

- f. Test, and if necessary, adjust the unit for proper operation, as follows:
  - (1) Connect the unit and test equipment as shown in Figure 2-1, but temporarily omit the input voltage source. Turn the trip point, ZERO, and DEADBAND potentiometers fully counterclockwise.
  - (2) Apply power input to the unit. Jumper +IN to common and adjust RI for 0V at pin 6 of ICI. Disconnect jumper and apply input voltage source.
  - (3) If the unit does not have the TT option, continue by connecting the voltage source and performing step (b) and the following steps in paragraph 2.2. If the unit does have the TT option, continue with step (4) in the present paragraph.

### MAINTENANCE INFORMATION

#### NOTE

Adjust the sealed potentiometers only if required to obtain the specified results.

- (4) Set the LOWER trip point dial to exactly 0. From a higher value, decrease the input voltage to exactly the 0% value. If the lower section of the unit is now in the untripped condition, adjust ZERO potentiometer when lower just trips.

#### NOTE

If the field selected resistor (FSR) does not allow for sufficient adjustment of the ZERO potentiometer proceed as follows:

- (1) Replace FSR with new FSR. Install Bourns switching device on FSR.
- (2) Set ZERO potentiometer to mid-range. Apply 0% input to the input terminals.
- (3) Set Bourns switching device for the exact resistance to read 0V at pin 6 of ICI.
- (4) When the exact value of resistance has been determined, note the resistance of the FSR selected by the switching device, then apply solder to the appropriate pads and their adjacent collectors.
- (5) Slowly increase the input voltage until the lower section of the unit just untrips and note the value of input voltage at which this occurs. Slowly decrease the input voltage until the lower section of the unit just trips again, which should occur at 0% input. The difference in values of input voltage at which the lower section of the unit untrips and trips must not be more than 1% of the input span of the unit. In addition, trip and untrip input voltages must each repeat within  $\pm 0.1\%$  of this same input voltage span when the procedure is repeated. Make sure that the lower section of the unit is in the tripped condition with 0% input voltage applied.

### MAINTENANCE INFORMATION

- (6) Turn the LOWER DEADBAND potentiometer fully clockwise, and then slowly increase the input voltage until the lower section of the unit just untrips. The voltage at which this occurs must be higher than the trip value in step (5) by not less than 10% of the input span of the unit.
- (7) If necessary, repeat steps (4), (5), and (6) to make sure that all specified conditions are met.
- (8) Set LOWER trip point dial to 100. From a higher value, decrease the input voltage to exactly the 100% value. If the lower section of the unit is now in the untripped condition, adjust R31 until the lower section just trips.
- (9) Set the UPPER trip point dial to 100. From a lower value, increase the input voltage to exactly the 100% value. If the upper section of the unit is not tripped, adjust R33 until the upper section just trips.
- (10) Slowly decrease the input voltage until the upper section of the unit just untrips, and note the value of input voltage at which this occurs. Slowly increase the input voltage until the upper section of the unit just trips again, which should occur at 100% input. The difference in values of input voltage at which the upper section of the unit untrips and trips must not be more than 1% of the input span of the unit. In addition, trip and untrip input voltages must each repeat within  $\pm 0.1\%$  of this same input voltage span when the procedure is repeated. Make sure that the upper section of the unit is in the tripped condition with 100% of the input voltage applied.
- (11) Turn the UPPER DEADBAND potentiometer fully clockwise, and then slowly decrease the input voltage until the upper section of the unit just untrips. The voltage at which this occurs must be lower than the trip value in Step (10) by not less than 10% of the input span of the unit.
- (12) If necessary, repeat steps (9), (10), and (11) to make sure that all specified conditions are met. When this is assured, carefully reseal the shaft of R31 with red Glyptal or equivalent, if required.



## SECTION 5

---

### MAINTENANCE INFORMATION

- g. When proper operation of the unit has been verified as in step (f) readjust the unit by the procedure given in Section 2. When the performance of the unit is known to be satisfactory, apply clear acrylic to reseal the unit where required.
- h. Check that all leads are clear of the board edge before reinstalling the board into its case.
- i. When reinstalling the unit onto the mounting bracket, be sure to use the same screws (or screws of the same size) as the ones removed. Longer screws will damage the unit.

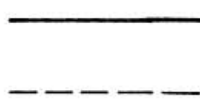
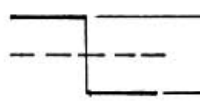
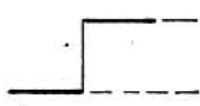
TABLE 5-1. WAVE FORMS AND AMPLITUDE

TEST POINT	WAVE FORM AND AMPLITUDE OR VOLTAGE LEVEL
1	 0 TO 1V DEPENDING ON INPUT 0V
2,5*	 +10V INPUT LESS THAN SET POINT 0 -10V INPUT GREATER THAN SET POINT
3,6*	 +6V (X2), +20V (X1) (X4)*, (X3)* 0
4,7*	 +20V (X2), (X4)* 0

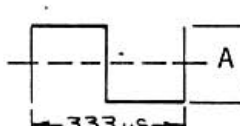
DC OPERATED UNITS			
TEST POINT	WAVE FORM	POWER INPUT AND WAVE FORM AMPLITUDE	
		24VDC	45VDC
(ON PCA BRD) A	 A 333μs	48V	90V

\* WAVE FORMS 5, 6, & 7 ARE FOR DUAL TRIP UNITS ONLY

\*\* WAVEFORM IS 0-5V FOR 0-5V INPUT & 0-10V FOR 0-10V INPUT.



REV. 1  
 K SEP 1952, 1959 / 1963  
 1/1 1000/10

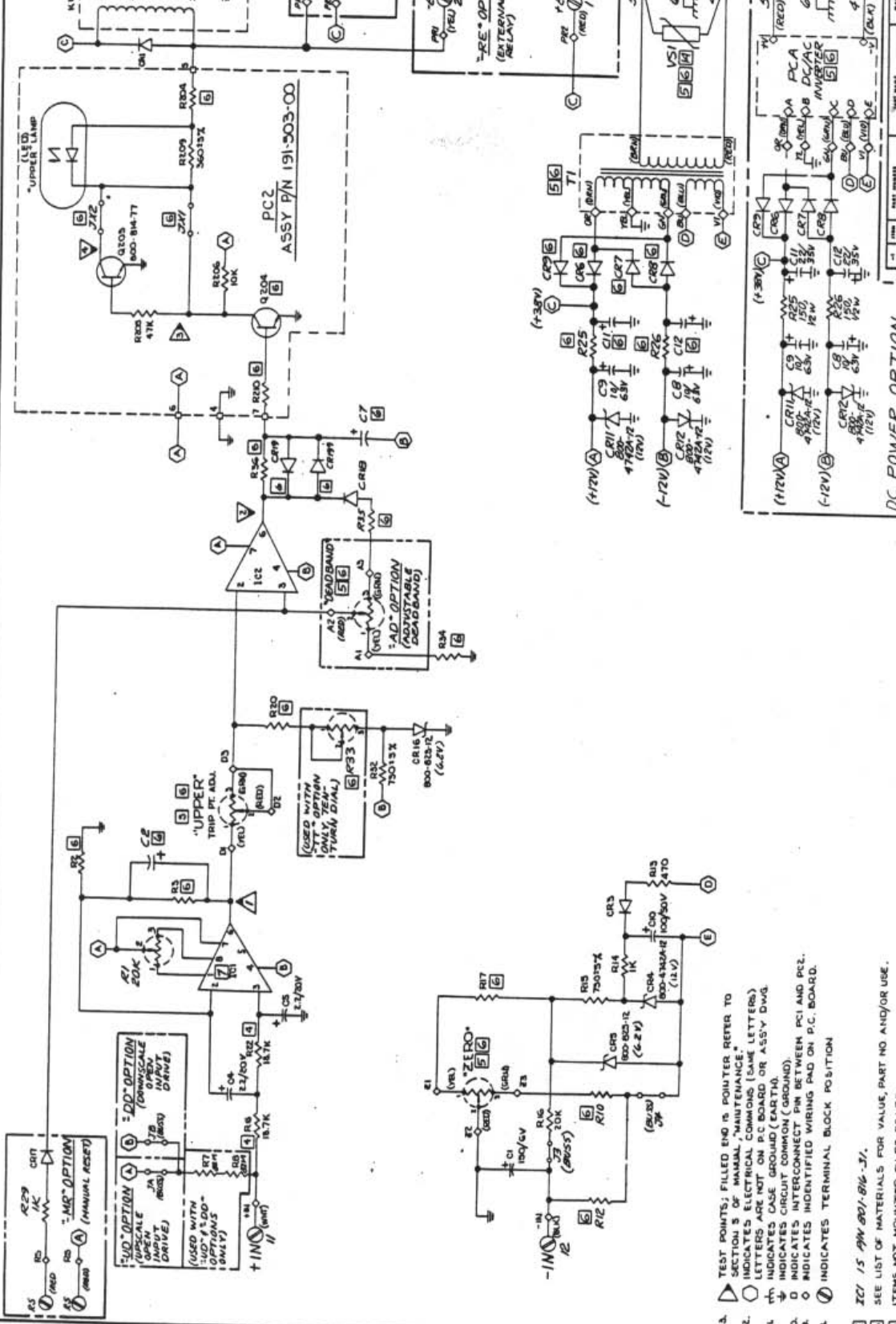

TEST POINTS; FILLED END IS POINTER REFER TO SECTION 5 OF MANUAL, "MAINTENANCE".  
 INDICATES ELECTRICAL COMMONS (SAME LETTERS).  
 LETTERS ARE NOT ON P.C. BOARD OR ASSY DWG.  
 INDICATES CASE GROUND (EARTH).  
 INDICATES CIRCUIT COMMON (GROUND).  
 INDICATES INTERCONNECT PIN BETWEEN P.C. BOARD AND P.C. BOARD.  
 INDICATES IDENTIFIED WIRING PAD ON P.C. BOARD.  
 INDICATES TERMINAL BLOCK POSITION.

ZC1 15 9W 801-816-3/1.

SEE LIST OF MATERIALS FOR VALUE, PART NO AND/OR USE.

ITEMS NOT MOUNTED ON P.C. BOARD.

METAL FILM RESISTOR 1%.  
 ALL POTENTIOMETERS INCREASE C.W. FROM 1 TO 3.  
 ALL INTD CKTS. ARE M.I. P.W. 800-823-1; DIODES ARE 800-484-1; RESISTORS ARE CARB. CH. 1% 10%.  
 RESISTANCE IN OHMS; CAPACITANCE IN MICROFARADS.  
 METAL FILM RESISTOR 1%.

NOTES - CONTINUED

FOR \*-RF\* OPTION VS1 BECOMES VS10, EXTERNALLY MOUNTED.

NOTES - CONTINUED

REV. 1	K SEP 1952, 1959 / 1963	1/1 1000/10
<p>SCHEMATIC STANDARD SINGLE MVA</p> <p>FOR PWT BEARING</p> <p>191-40100K</p>		
<p>191-501-00</p>		



REV.	DESCRIPTION	DATE	BY	APPROV.

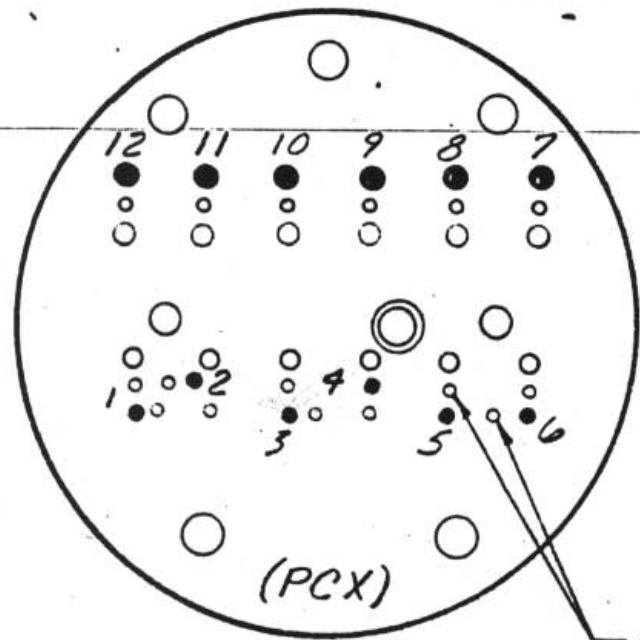

VSI  
"SP CASE"

MTG. HOLES FOR VSI

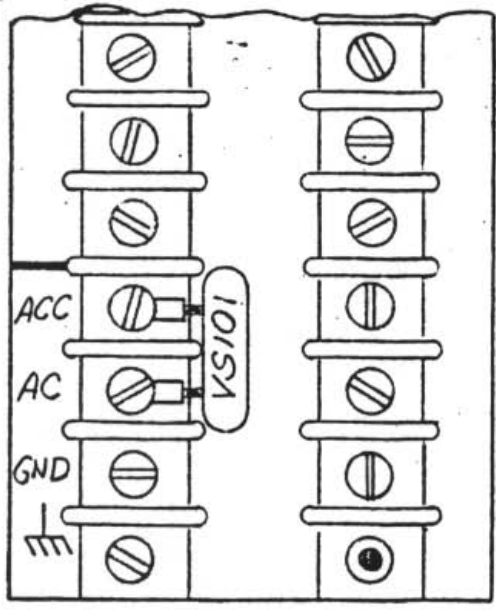

VSI101

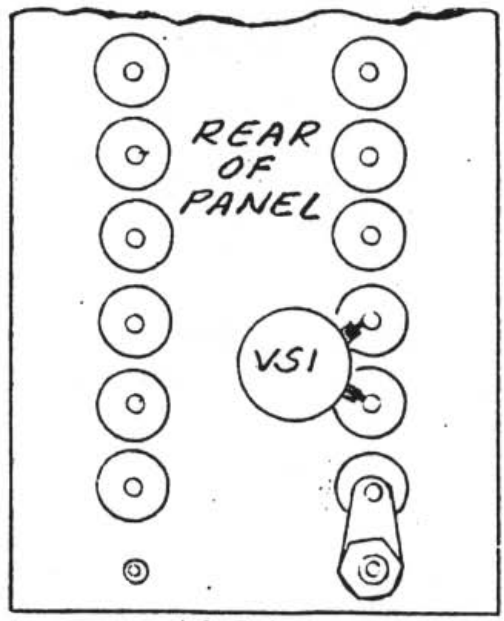

VSI  
(SLEEVE LEADS)

"SR CASE"

DIMENSIONS ARE IN INCHES UNLESS NOTED OTHERWISE TOLS. UNLESS NOTED: .X = ± .10 .XX = ± .030 .XXX = ± .010 ANGLES = ± 30°	DRAWN <i>R. Kelley</i> 1/24/74	MOORE INDUSTRIES INC. VAN NUYS, CA.	STANDARD MVA SINGLE TRIP (ADDITIONAL PARTS LOCATION)
	CHECKED <i>C.F.</i> 1/29/74		
DO NOT SCALE DRAWING	CUSTMR.	DWG. NO. 191-501-00	REV. K
SCALE: <i>X</i>	P6.292	191-501-00	P6.292





C-1853

REV.	DESCRIPTION	DATE	BY	APPROV.
F	PER ECO.6422	6/30/87	JAD	WJm

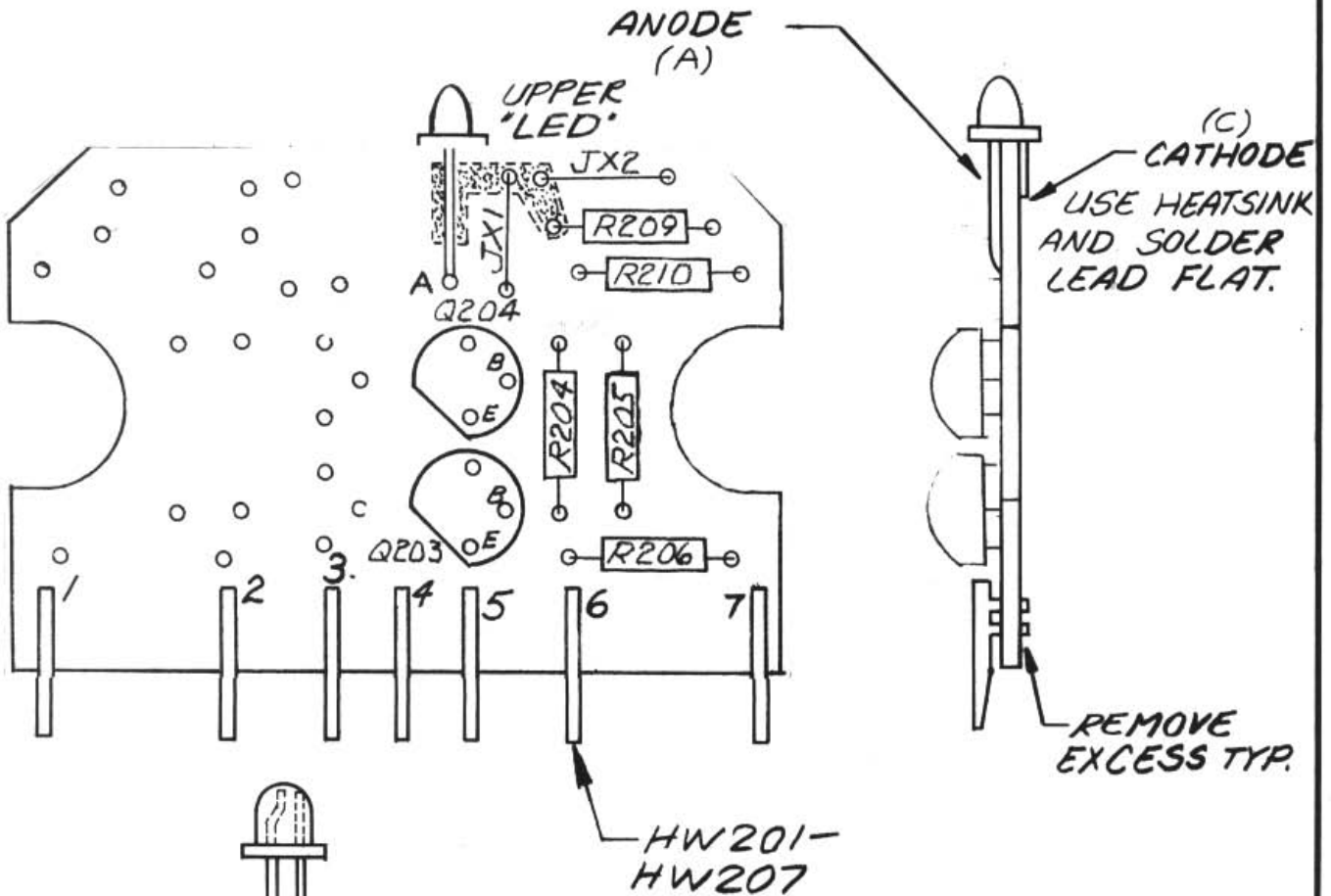
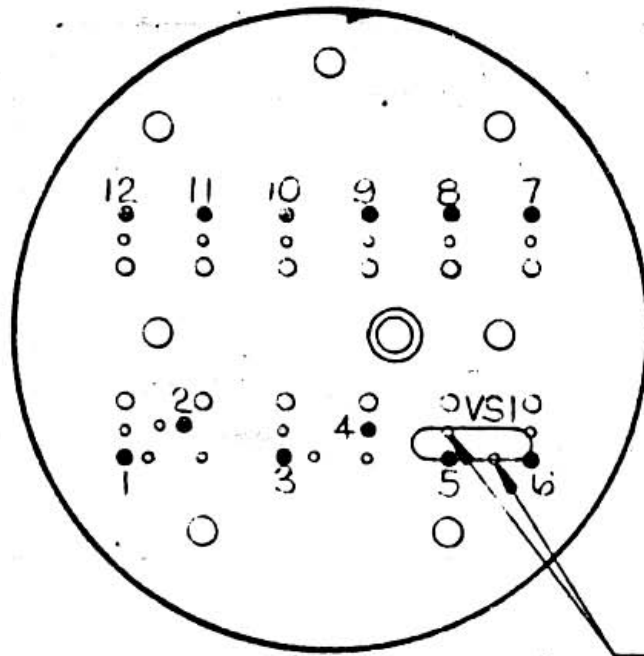

FIG. A  
LEAD IDENTIFICATION

2. SEE FIG. A FOR "LED" LEAD I. D.; ANODE TO PAD "A," CATHODE TO PAD "C"
1. ALL JUMPERS 22 AWG BUSS TEFLON SLEEVED.

NOTES: UNLESS OTHERWISE SPEC'D.

DIMENSIONS ARE IN INCHES UNLESS NOTED OTHERWISE	DRAWN	A. MUNGUIA	10/10/83	<b>MOORE INDUSTRIES INC.</b> VAN NUYS ■ CA.	<b>BOARD ASSEMBLY STD.</b> <b>MVA PC2</b> <b>SINGLE TRIP (AC OR DC POWERED)</b>
	CHECKED				
TOLS. UNLESS NOTED: .X = ± .10 .XX = ± .030 .XXX = ± .010 ANGLES = ± 30'	PROJ. ENGR.	<i>WJm</i>		DWG. NO.	191-503-00
	DO NOT SCALE DRAWING			REV	F
SCALE: 2:1	CUSTMR.				



VSI  
"SP" CASE

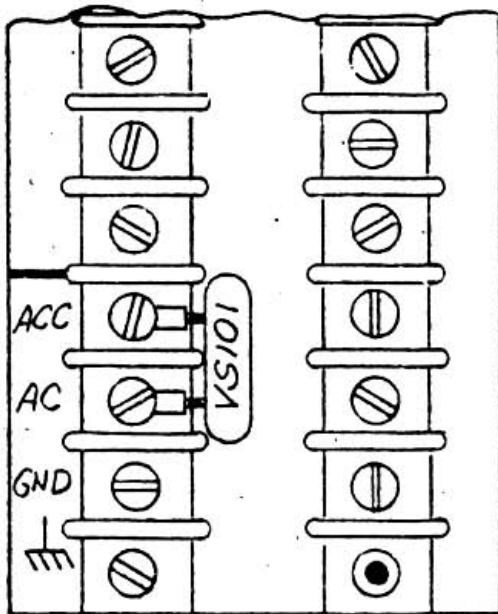

VSI01

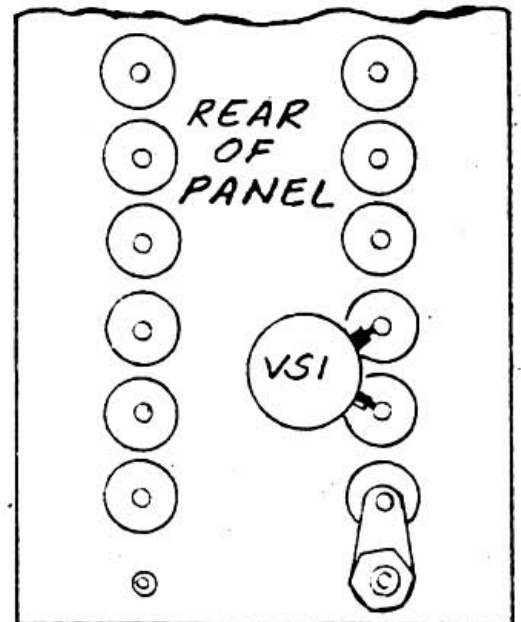

VSI  
(SLEEVE LEADS)

"SR CASE"

DIMENSIONS ARE IN INCHES UNLESS NOTED OTHERWISE

TOLS. UNITS NOTED:  
 .X = ± .10  
 .XX = ± .030  
 .XXX = ± .010  
 ANGLES = ± 30°

DO NOT SCALE DRAWING

SCALE:  $\approx$

DRAWN	<i>R. Kelley</i>	<i>1/29/74</i>
CHECKED	<i>C.F.</i>	<i>1/29/74</i>
PROJ. ENGR.	<i>1/29/74</i>	
CUSTOMER		

**MOORE INDUSTRIES INC.**  
 VAN NUYS ■ CA.

**STANDARD MVA DUAL TRIP**  
 (ADDITIONAL PARTS LOCATION)

DWG. NO. **191-502-00**      **P6.282**      REV. **N**

C-1896

REV.	DESCRIPTION	DATE	BY	APPROV.
F	PER ECO 6422	6/30/69	JAD	wjm

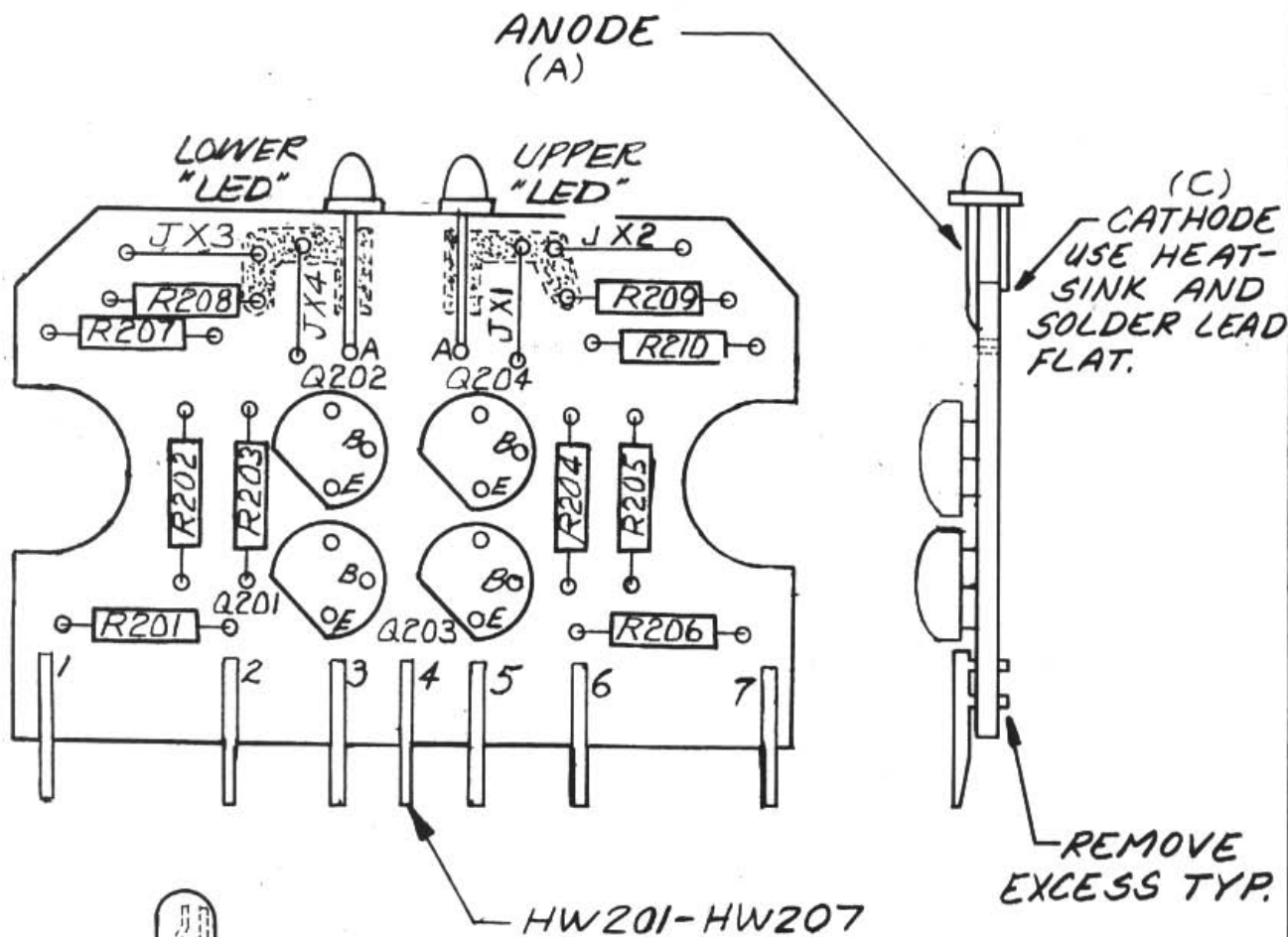

FIG. A  
LEAD IDENTIFICATION

2. SEE FIG. A FOR "LED" LEAD I. D.; ANODE TO PAD "A", CATHODE TO PAD "C".

1. ALL JUMPERS 22 AWG BUSS, TEFLON SLEEVED AS REQ'D.

NOTES: UNLESS OTHERWISE SPEC'D.

DIMENSIONS ARE IN INCHES UNLESS NOTED OTHERWISE	DRAWN	A. MUNGUIA	10/15/73	<b>MOORE INDUSTRIES INC.</b> VAN NUYS ■ CA.			
	CHECKED						
TOLS. UNLESS NOTED: .X = ± .10 .XX = ± .030 .XXX = ± .010 ANGLES = ± 30°	PROJ. ENGR.	<i>Al Belle</i>		P.C. BOARD ASS'Y. STD. MVA PC2 DUAL TRIP			
	DO NOT SCALE DRAWING						
SCALE:	CUSTOMR.			DWG. NO.	191-504-00	REV.	F



## RETURN PROCEDURES

### To return equipment to Moore Industries for repair, follow these four steps:

1. Call Moore Industries and request a Returned Material Authorization (RMA) number.

#### Warranty Repair –

If you are unsure if your unit is still under warranty, we can use the unit's serial number to verify the warranty status for you over the phone. Be sure to include the RMA number on all documentation.

#### Non-Warranty Repair –

If your unit is out of warranty, be prepared to give us a Purchase Order number when you call. In most cases, we will be able to quote you the repair costs at that time. The repair price you are quoted will be a "Not To Exceed" price, which means that the actual repair costs may be less than the quote. Be sure to include the RMA number on all documentation.

2. Provide us with the following documentation:
  - a) A note listing the symptoms that indicate the unit needs repair
  - b) Complete shipping information for return of the equipment after repair
  - c) The name and phone number of the person to contact if questions arise at the factory
3. Use sufficient packing material and carefully pack the equipment in a sturdy shipping container.
4. Ship the equipment to the Moore Industries location nearest you.

The returned equipment will be inspected and tested at the factory. A Moore Industries representative will contact the person designated on your documentation if more information is needed. The repaired equipment, or its replacement, will be returned to you in accordance with the shipping instructions furnished in your documentation.

#### WARRANTY DISCLAIMER

THE COMPANY MAKES NO EXPRESS, IMPLIED OR STATUTORY WARRANTIES (INCLUDING ANY WARRANTY OF MERCHANTABILITY OR OF FITNESS FOR A PARTICULAR PURPOSE) WITH RESPECT TO ANY GOODS OR SERVICES SOLD BY THE COMPANY. THE COMPANY DISCLAIMS ALL WARRANTIES ARISING FROM ANY COURSE OF DEALING OR TRADE USAGE, AND ANY BUYER OF GOODS OR SERVICES FROM THE COMPANY ACKNOWLEDGES THAT THERE ARE NO WARRANTIES IMPLIED BY CUSTOM OR USAGE IN THE TRADE OF THE BUYER AND OF THE COMPANY, AND THAT ANY PRIOR DEALINGS OF THE BUYER WITH THE COMPANY DO NOT IMPLY THAT THE COMPANY WARRANTS THE GOODS OR SERVICES IN ANY WAY.

ANY BUYER OF GOODS OR SERVICES FROM THE COMPANY AGREES WITH THE COMPANY THAT THE SOLE AND EXCLUSIVE REMEDIES FOR BREACH OF ANY WARRANTY CONCERNING THE GOODS OR SERVICES SHALL BE FOR THE COMPANY, AT ITS OPTION, TO REPAIR OR REPLACE THE GOODS OR SERVICES OR REFUND THE PURCHASE PRICE. THE COMPANY SHALL IN NO EVENT BE LIABLE FOR ANY CONSEQUENTIAL OR INCIDENTAL DAMAGES EVEN IF THE COMPANY FAILS IN ANY ATTEMPT TO REMEDY DEFECTS IN THE GOODS OR SERVICES, BUT IN SUCH CASE THE BUYER SHALL BE ENTITLED TO NO MORE THAN A REFUND OF ALL MONIES PAID TO THE COMPANY BY THE BUYER FOR PURCHASE OF THE GOODS OR SERVICES.

ANY CAUSE OF ACTION FOR BREACH OF ANY WARRANTY BY THE COMPANY SHALL BE BARRED UNLESS THE COMPANY RECEIVES FROM THE BUYER A WRITTEN NOTICE OF THE ALLEGED DEFECT OR BREACH WITHIN TEN DAYS FROM THE EARLIEST DATE ON WHICH THE BUYER COULD REASONABLY HAVE DISCOVERED THE ALLEGED DEFECT OR BREACH, AND NO ACTION FOR THE BREACH OF ANY WARRANTY SHALL BE COMMENCED BY THE BUYER ANY LATER THAN TWELVE MONTHS FROM THE EARLIEST DATE ON WHICH THE BUYER COULD REASONABLY HAVE DISCOVERED THE ALLEGED DEFECT OR BREACH.

#### RETURN POLICY

For a period of thirty-six (36) months from the date of shipment, and under normal conditions of use and service, Moore Industries ("The Company") will at its option replace, repair or refund the purchase price for any of its manufactured products found, upon return to the Company (transportation charges prepaid and otherwise in accordance with the return procedures established by The Company), to be defective in material or workmanship. This policy extends to the original Buyer only and not to Buyer's customers or the users of Buyer's products, unless Buyer is an engineering contractor in which case the policy shall extend to Buyer's immediate customer only. This policy shall not apply if the product has been subject to alteration, misuse, accident, neglect or improper application, installation, or operation. THE COMPANY SHALL IN NO EVENT BE LIABLE FOR ANY INCIDENTAL OR CONSEQUENTIAL DAMAGES.



**WORLDWIDE • www.miinet.com**

United States • info@miinet.com Tel: (818) 894-7111 • FAX: (818) 891-2816	Belgium • info@mooreind.be Tel: 03/448.10.18 • FAX: 03/440.17.97	China • sales@mooreind.sh.cn Tel: 86-21-62491499 • FAX: 86-21-62490635
Australia • sales@mooreind.com.au Tel: (02) 8536-7200 • FAX: (02) 9525-7296	The Netherlands • sales@mooreind.nl Tel: (0)344-617971 • FAX: (0)344-615920	United Kingdom • sales@mooreind.com Tel: 01293 514488 • FAX: 01293 536852